

# 4-wheel electric tow tractor

## TE501

Towing capacity 50000 kg



4-wheel tow tractor, with on-board operator. Heavy-duty high-performance and long-range truck for industrial and airport duties. Despite its small size and turning radius, the TE501 has a 50-tonne towing capacity. Loading capacity of wide rear platform 200 kg.

- New **supporting perimeter chassis** ensures maximum exploitation of AC motor torque and optimum stability.
- **Suspensions:** steel coil springs, stabiliser bar and shock absorbers in the front, rubberised springs with hydraulic shock absorber in the rear.
- **Service brake pedal**, acting on 4 wheels - with twofold braking system. Front disk brakes and rear oil-bath multiple-disk brakes.

Standard negative hydraulic parking brake.

Preset electrical **braking**, operating automatically when accelerator pedal is released, with first stroke of brake pedal and when reversing direction.

- Standard hydraulic **steering**.
- **2 operators on board.** Comfortable driving position in the front ensures excellent front and rear visibility. Standard mechanical suspension seats. Easy access to driving position thanks to low step-on platform.
- **“Man on board” device** with seat occupancy sensor. Horn.
- **Digital dashboard** with battery charge indicator, fault detection, speedometer, steering angle indicator, speed profile selection, odometer and hour meter.

- **New generation AC electric motor.**
- **Electronic AC control** with energy recovery and braking during deceleration.
- Several towing hitches available. Rear inching control to ease coupling operations.
- DIN 43536A 80 V battery with 620 Ah capacity - fast vertical replacement.

#### Available options:

Pneumatic, superelastic or non-marking **tyres**. **Full cab** with sliding side doors, flat front windscreen, rear window, electric wiper, sun visor, integrated light system in the cabin with 2 front lights (dipped-beam/main-beam), 2 front turn indicators, rear lights on the back of the cab in high anti-collision position (position/brake/reversing lights/turn indicators), 2 exterior rearview mirrors – full-LED lights. Available also without doors, with canvas doors or hinged doors.

Electric **heater**; air conditioning (cooling).

**Flashing light** and blue safety light.

Standard paint finish: chassis dark grey RAL 7021/body light grey RAL 7035. Other colours available upon request.

All parts are easy to access for fast and effective maintenance. Lower costs due to AC technology and modular design.

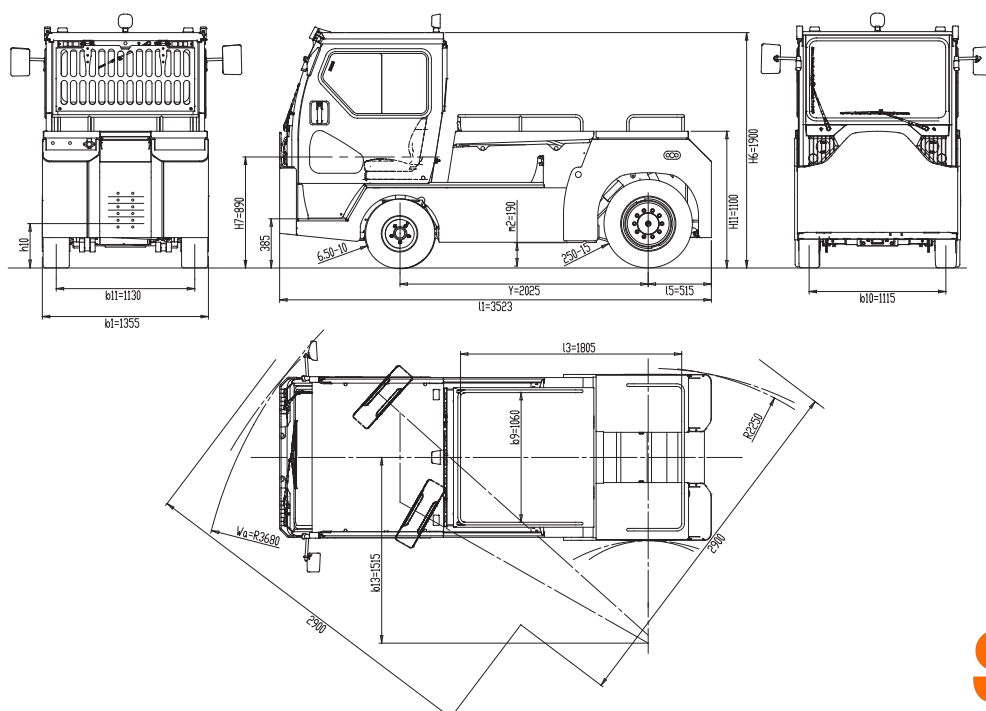

FEATURES	1.1	Manufacturer			SIMAI S.p.A.
	1.2	Model			TE501
	1.3	Drive			Electric
	1.4	Operator Type			Sitting driver
	1.5	Load Capacity	Q	t	0,2
	1.5.1	Towing Capacity	Q	t	50
	1.7	Rated Drawbar pull	F	N	10000
	1.9	Wheelbase	Y	mm	2025
	WEIGHTS	2.1	Service weight (w/battery)		Kg
2.2		Axle loading laden front/rear (with operator 80 kg. each)		Kg	2570 / 3490
2.3		Axle loading unladen front/rear		Kg	2370 / 3330
TYRES - CHASSIS	3.1	Tyres:Cushion(Cu),Superelastic(SE), Pneus(Pn) Poliurethane (PE)			SE/Pn
	3.2	Tyre size front			6.50-10
	3.3	Tyre size rear			250-15
	3.5	Wheels nr. Front/Rear (X=motive)			2 / 2X
	3.6	Tread front	b <sub>10</sub>	mm	1115
	3.7	Tread rear	b <sub>11</sub>	mm	1130
	DIMANSSIONS	4.7	Height of roof/cabin	h <sub>6</sub>	mm
4.8		Seat height	h <sub>7</sub>	mm	890
4.8.1		Step on platform height		mm	385
4.12		Coupling height	h <sub>10</sub>	mm	345 - 400 - 455 - 510 -565
4.13		Loading height (min / MAX)	h <sub>11</sub>	mm	1100
4.16		Platform length	l <sub>3</sub>	mm	1800
4.17		Rear overhang	l <sub>5</sub>	mm	515
4.18		Platform width	b <sub>9</sub>	mm	1060
4.19		Overall length	l <sub>1</sub>	mm	3523
4.21		Overall width	b <sub>1</sub>	mm	1355
4.32		Ground clearance - centre of wheelbase	m <sub>2</sub>	mm	190
4.35		Turning radius front	Wa	mm	3680
4.35.1		Turning radius rear		mm	2250
4.36		Turning radius inner	b <sub>13</sub>	mm	1515
4.36.1		Aisle width when turning 90°		mm	2900
PERFORMANCES		5.1	Travel speed laden/unladen		Km/h
	5.5	Drawbar pull laden		N	-
	5.5.1	Drawbar pull unladen		N	10000
	5.6	Max. Drawbar pull laden/unladen		N	- / 29000
	5.7	Gradeability laden/unladen		%	See chart
	5.8	Max. Gradeability laden/unladen		%	
	5.10	Service / Parking brake (I=Hydraulic E=Electromagn. M=Mechanical)			I / I
	5.10.1	Type of service brake front/rear			Disk / wet brakes
MOTOR	6.1	Drive motor rating S2=60 min		kW	26
	6.1.1	Hydrauling steering motor rating S2=60 min		kW	1
	6.3	Battery according to DIN 43531 / 35 / 36 A, B, C, no			DIN 43536A
	6.4	Battery voltage	U	V	80
	6.4.1	Battery rated capacity	K <sub>S</sub>	Ah	840 - 930
	6.5	Battery weigth		Kg	<b>2208 - 2288</b>
	6.6	Energy consumption (VDI cycle)		kWh/h	-
OTHER DATA	8.1	Drive Control			inverter AC
	8.4	Sound level at driver's ear according to DIN 12053		dB(A)	69
	8.5	Towing coupling, type DIN			-

As per VDI guidelines 2198, this datasheet applies to standard electric tractor / platform truck only. Dimensions are not binding and can be changed in any moment. The performances must be intended for brand new machines, after having completed the running-in tested in San Donato Milanese Factory in normal climatic conditions. Performances and weight are to be intended with standard motors and battery (reported in bold) and with extra-elastic tires. Some data can vary according to different equipments.



**Simai S.p.A.**

Via Civesio, 10 • 20097 S. Donato Milanese (MI) • Italy  
T +39 02 94424211 • F +39 02 5231082 • info@simai.it



**Simai**<sup>®</sup>  
www.simai.it

0555E1120